

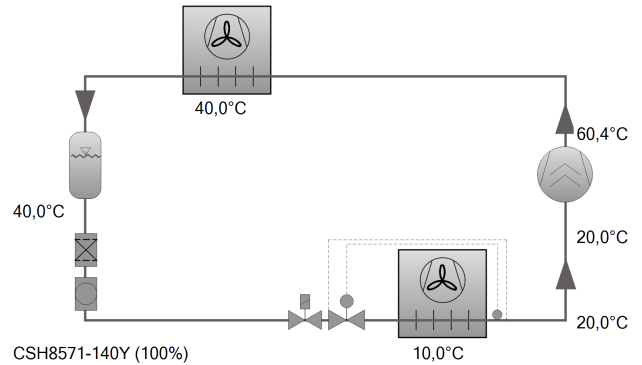

### Selection: Compact Screw Compressors CS // CSV

#### Input Values

Compressor model	(CSH8571-140Y)
Refrigerant	R134a
Reference temperature	Dew point temp.
Evaporating SST	10,00 °C
Condensing SDT	40,0 °C
Liq. subc. (in condenser)	0 K
Suct. gas superheat	10,00 K
Useful superheat	100%
Operating mode	Standard
Power supply	400V-3-50Hz
Capacity control	100%
Additional cooling	Automatic
Max. discharge gas temp.	110,0 °C



#### Result

Compressor	CSH8571-140Y-40P
Capacity steps	100%
Cooling capacity	339 kW
Cooling capacity *	339 kW
Evaporator capacity	339 kW
Power input	62,1 kW
Current (400V)	113,2 A
Voltage range	380-415V
Condenser capacity	401 kW
COP/EER	5,45
COP/EER *	5,45
Mass flow LP	7780 kg/h
Mass flow HP	7780 kg/h
Operating mode	Standard
Liquid temp.	40,0 °C
Oil volume flow	0,71 m³/h
Cooling method	--
Discharge gas temp. w/o cooling	60,4 °C

\*According to EN12900 (10K suction gas superheat, 0K liquid subcooling, see tech. data/ notes)

#### Application Limits Standard CSH8571-140

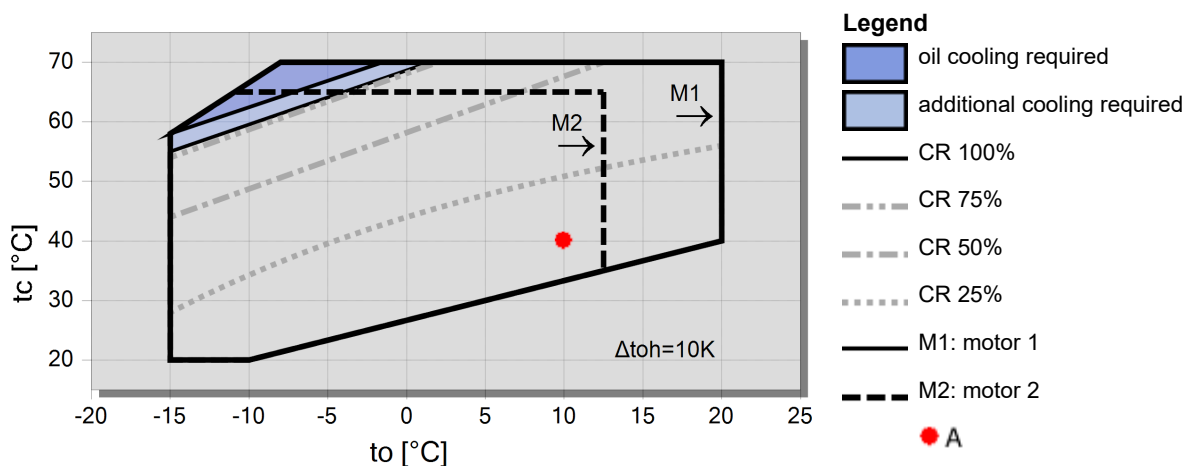



## Technical Data: (CSH8571-140Y)

### Dimensions and Connections

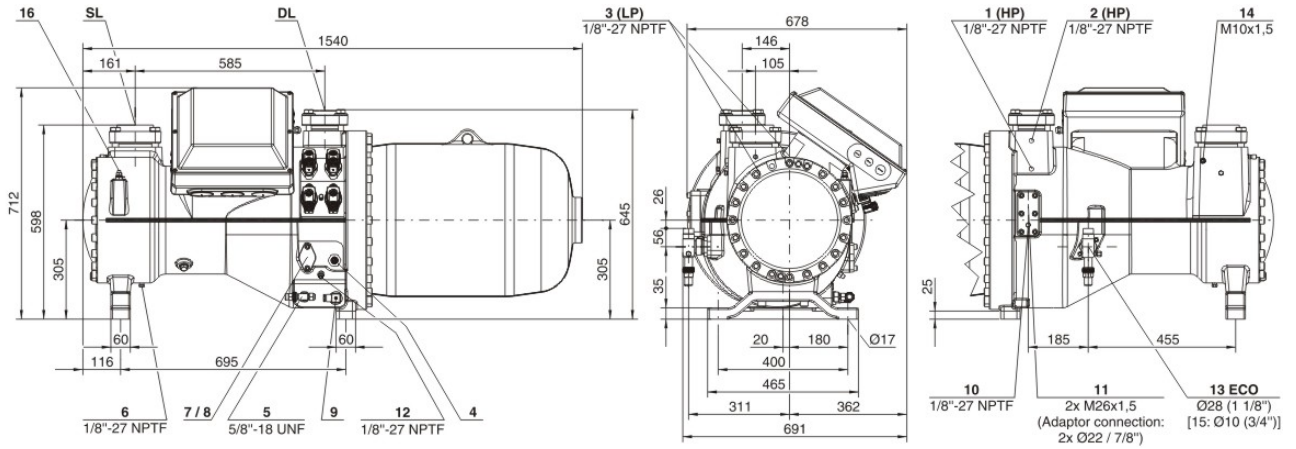



## Technical Data

### Technical Data

Displacement (2900rpm 50 Hz)	410 m <sup>3</sup> /h
Displacement (3500rpm 60 Hz)	495 m <sup>3</sup> /h
Weight	860 kg
Max. pressure (LP/HP)	19 / 28 bar
Connection suction line	DN 100
Connection discharge line	76 mm - 3 1/8"
Oil type R134a/R407C/R404A/R507A/R407A/R407F	BSE170 (Option)
Oil type R22	B320SH (Standard)

### Motor data

Motor version	1
Motor voltage (more on request)	380-415V PW-3-50Hz
Max. operating current	246.0 A
Winding ratio	50/50
Starting current (Rotor locked)	665.0 A D / 1023.0 A DD
Max. power input	150,0 kW

### Extent of delivery (standard)

Enclosure class	IP54
Oil heater	300 W (Standard)
Oil separator	Standard
Oil filter	Standard
Discharge gas temperature sensor	Standard
Start unloading	Standard
Capacity Control - 4-step	100-75-50-25% (Standard)
Capacity Control - infinite	100-25% (Standard)
Built-in check valve	Standard
Motor protection	SE-E1 (Standard), INT69VSY-II(Standard for 660-690V)
Oil charge	22,0 dm <sup>3</sup>

### Available options

Oil level switch	Option
Discharge shut-off valve	Option
Suction shut-off valve	Option
Shut-off valve for ECO with muffler	Option
Liquid injection with integrated nozzle	Option
Bridges for DOL start	Option
Vibration dampers	Option



## Compact Screw Compressors CS

### Reference points for evaporating and condensing pressures

Connection positions 1 (HP) and 3 (LP) on the compressor (see dimensions). The pressure drop for shut-off valves and check valves has not been taken into consideration. This is the worldwide state of the art for compact screws, as in factory-produced chillers shut-off valves are often omitted and the check valve can also be arranged as an external component in the discharge line. For the sake of the international comparability of performance data, this standard has been adopted for the screw compressors of the CSH/CSW/CSVH series.

### ASERCOM certified performance data

The Association of European Refrigeration Component Manufacturers has implemented a procedure of certifying performance data. The high standard of these certifications is assured by:

- \* plausibility tests of the data performed by experts.
- \* regular measurements at independent institutes.

These high efforts result in the fact that only a limited number of compressors can be submitted. Due to this not all BITZER compressors are certified up to now. Performance data of compressors which fulfil the strict requirements may carry the label "ASERCOM certified". In this software you will find the label at the respective compressors on the right side below the field "result" or in the print out of the performance data. All certified compressors and further information are listed on the homepage of ASERCOM.